

Distributed Grover for Detecting Cycles in the CONGEST model

Maël Luce

January 26th, 2024

CONGEST model

Abstraction of a network by a graph G :

- Node u : computer. $|V| = n$
- Edge e : communication channel.

To answer a problem, each node:

- knows the value of n
- can differentiate its edges.
- has a unique arbitrary identifier taken in $\text{poly}(n)$.
- can output something.

Algorithms in the model

Algorithm defined for every node, for every network.

Synchronous rounds for all the nodes.

- 1 $O(\log n)$ bits sent and received along each edge
- 2 private computation

Round complexity: asymptotic number of rounds for the worst possible graph when $n \rightarrow \infty$.

Example: Leader Election [Peleg90]

Required output: each node must know at the end of the algorithm if it is the unique leader.

Algorithm for each node u :

Initial setup: $m(u) = \text{ID}(u)$

Every round:

- 1 send $m(u)$ to all neighbors
- 2 if received $m(v) < m(u)$, update $m(u) = m(v)$

Round complexity: In D rounds, for any node u , $m(u) = \min_{v \in V} \text{ID}(v)$.

Smallest ID is the leader.

Example: Leader Election

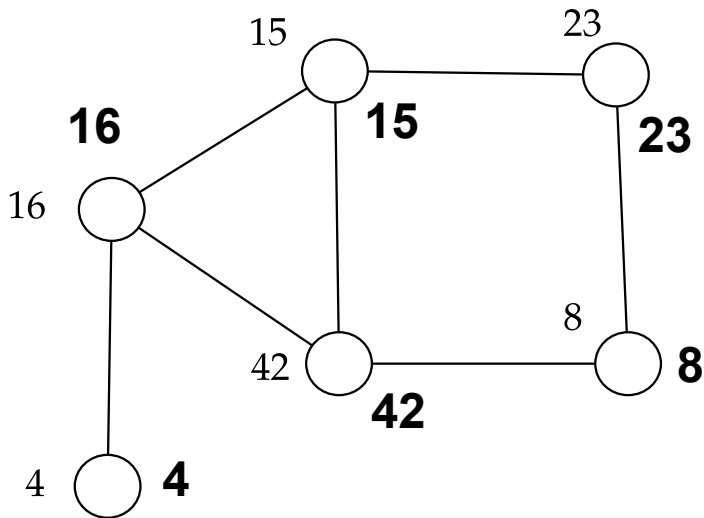

Initial setting

Example: Leader Election

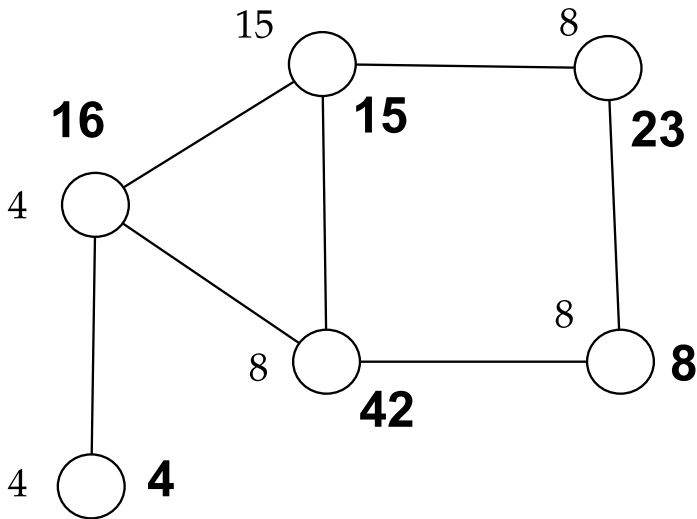

After 1 round

Example: Leader Election

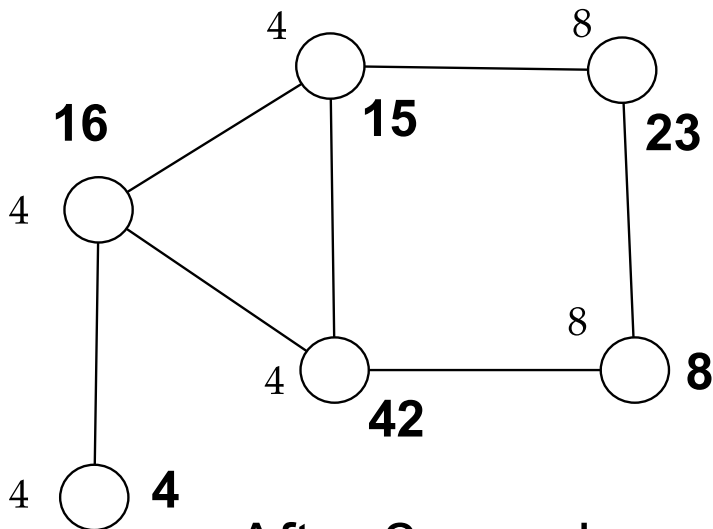

Example: Leader Election

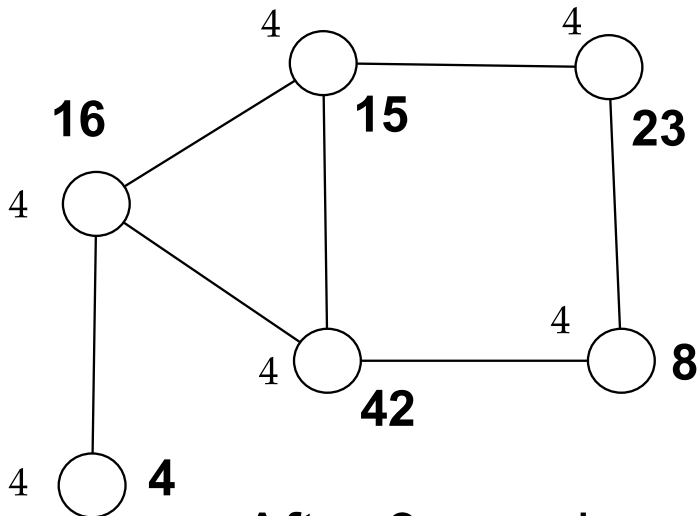

Centralized Grover

Function $f : X \rightarrow \{0, 1\}$.

Probability $\geq \epsilon$ of sampling $x \in X, f(x) = 1$.

Start from uniform superposition and repeat $\Theta(\sqrt{\frac{1}{\epsilon}})$ times:

- 1 Apply O_f : reflection through items $x, f(x) = 0$.
- 2 Apply R_0 : reflection through uniform superposition.

Measure to yield $x \in X, f(x) = 1$.

Distributed version [GM18]

Centralized:

repeat $O(\sqrt{\frac{1}{\epsilon}})$ reflections:

- 1 oracle for f
- 2 uniform superposition

Distributed: Centralized by leader.

repeat $O(\sqrt{\frac{1}{\epsilon}})$ reflections:

- 1 **distributed** oracle for f
- 2 uniform superposition

Analogy works because:

classical procedure \rightarrow classical circuit \rightarrow reversible classical circuit \rightarrow
quantum circuit \rightarrow quantum oracle

Distributed Grover Theorem

X arbitrary set, $f : X \rightarrow \{0, 1\}$ s.t. :

- sampling $x \in X$ s.t. $f(x) = 1$ has probability either 0 or $\geq \epsilon$.
- two classical distributed procedures:
 - 1 **Init:** electing a leader in D rounds.
 - 2 **Check:** decide if $f(x) = 1$ for any x , in r rounds.

Theorem (Distributed Grover [GM18])

There is a quantum algorithm deciding if $\exists x, f(x) = 1$ in $\tilde{O}(D + \sqrt{\frac{1}{\epsilon}} \cdot r)$ rounds with probability $1 - 1/\text{poly}(n)$ by electing a leader that outputs such an item x .

Complexity Results

Problem	Classical	Quantum	Citation
Diameter computation	$\tilde{\Theta}(n)$	$\tilde{O}(\sqrt{nD})$	[GM18]
Triangle detection	$\tilde{O}(n^{1/3})$	$\tilde{O}(n^{1/5})$	[CFGLO22]
Clique detection	$\tilde{O}(n^{1-2/p})$	$\tilde{O}(n^{1-2/(p-1)})$	[CFGLO22]

Table: Round complexity for quantumly sped up problems

H-freeness and diameter reduction

Theorem (Diameter reduction [EFFKO19])

Let F be any fixed, connected k -vertex graph. Let \mathcal{A} be a randomized (resp. quantum) algorithm that solves F -freeness for n -node graphs of diameter at most D with $T(n, D)$ round complexity and error probability $\rho = o(1/(n \log n))$. There is a randomized (resp. quantum) algorithm \mathcal{A}' that solves F -freeness with round complexity $\tilde{O}(T(n, O(k \log n)) + k \log^2 n)$ and error probability at most $(c\rho n \log n + 1/\text{poly}(n))$, for some constant c .

A p -cycle is a cycle of length p .

C_p -freeness problem:

- If G contains a p -cycle, at least one node must *reject*.
- All nodes *accept* otherwise.

Color-coding

Repeat $\tilde{\Theta}(1)$ times:

① Nodes \leftarrow color u.a.r. in $[0, 4]$.

② .

③ .

.

.

④ .

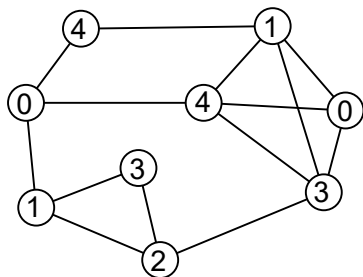

Color-coding

Repeat $\tilde{\Theta}(1)$ times:

- 1 Nodes \leftarrow color u.a.r. in $[0, 4]$.
- 2 Nodes colored 0 send own ID.
- 3 Received ID forwarded.
from color 1 to 2.
and from 4 to 3 to 2.
- 4 Color 2 detects cycle.

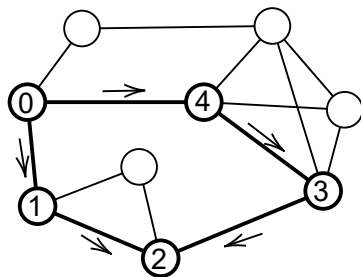

Color-coding

$\Omega(n)$
complexity

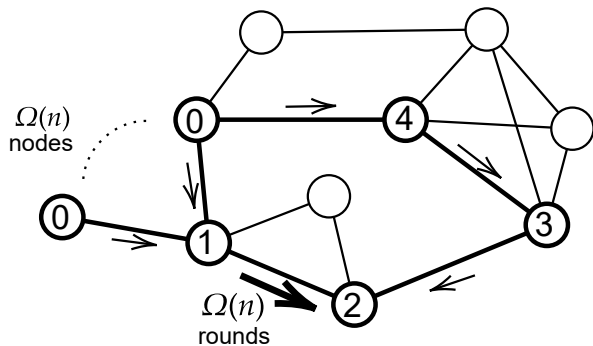

Complexity of C_{2k+1} -freeness

Model	Problem	Classical	Quantum
2-party	Set-Disjointness	$\Omega(N)$	$\tilde{\Omega}(r + \frac{N}{r})$ [BGKMT15]
CONGEST	C_{2k+1} -freeness	$\tilde{\Omega}(n)$ [DKO14]	$\tilde{\Omega}(\sqrt{n})$

Table: Lower bounds

\implies Color-coding is optimal in the classical setting!

What is optimal in a quantum setting ?

Quantum Complexity of C_{2k+1} -freeness

Quantum algorithm:

- 1 Elect a leader.
- 2 Set X of identifiers in the graph.
- 3 Color-coding as the checking.

$\tilde{O}(\sqrt{n})$ rounds. **Optimal !**

Quantum Complexity of C_{2k+1} -freeness

Quantum algorithm:

- 1 Elect a leader.
- 2 Set X of identifiers in the graph.
- 3 Color-coding as the checking.

$\tilde{O}(\sqrt{n})$ rounds. **Optimal !**

CHEATER !

The problem and the solution

The leader cannot sample identifiers !

Solution:

- **Modified Color-coding:** nodes colored 0 only have probability $1/n$ of sending ID.
- 1-sided error algorithm: success probability $\Omega(1) \rightarrow \Omega(1/n)$, complexity $\Theta(n) \rightarrow O(1)$.
- $f : \{\text{runs modified color-coding}\} \rightarrow \{\text{accept, reject}\}$.

NB: Similar quantizing for C_{2k} -freeness: from $O(n^{1-1/k})$ to $\tilde{O}(\sqrt{n^{1-1/k}})$.

Conclusion

- **Short-term:** What else can distributed Grover help speedup ? More H -freeness problems ?

- **Long-term:** Can there exist another type of quantum advantage in the CONGEST model ?

References



David Peleg (1990)

Time-optimal Leader Election in General Networks
Journal of Parallel and Distributed Computing, Volume 8, Issue 1



Andrew Drucker, Fabian Kuhn, Rotem Oshman (2014)

On the power of the congested clique model
PODC'14



Mark Braverman, Ankit Garg, Young Kun Ko, Jieming Mao, Dave Touchette (2015)

Near-optimal bounds on the bounded-round quantum communication complexity of disjointness
IEEE 2015



François Le Gall, Frédéric Magniez (2018)

Sublinear-Time Quantum Computation of the Diameter in CONGEST Networks
PODC'18



François Le Gall, Frédéric Magniez (2018)

Sublinear-Time Quantum Computation of the Diameter in CONGEST Networks
PODC'18



Talya Eden, Nimrod Fiat, Orr Fischer, Fabian Kuhn, and Rotem Oshman (2019)

Sublinear-Time Distributed Algorithms for Detecting Small Cliques and Even Cycles
DISC 2019



Taisuke Izumi, François Le Gall, Frédéric Magniez (2020)

Quantum Distributed Algorithm for Triangle Finding in the CONGEST Model
STACS 2020



Keren Censor-Hillel, Orr Fischer, François Le Gall, Dean Leitersdorf, Rotem Oshman (2022)

Quantum Distributed Algorithms for Detection of Cliques
ITCS 2022